



WATER SERVICES  
ASSOCIATION OF AUSTRALIA

# WSA 137:2019

Industry standard for Unplasticized poly(vinyl chloride) (PVC-U), polypropylene (PP) and Polyethylene (PE) maintenance shafts, maintenance chambers and maintenance holes for sewerage

(Incorporating Amd 1, 2 and 3)

**Issue 3.3**



## **ACKNOWLEDGMENTS**

---

The WSAA Board would like to express its appreciation to WSAA Members and staff for their contributions to the development of this Standard. Contributions from other industry organisations and individuals are also gratefully acknowledged.

## **PUBLICATION HISTORY**

Issue 3.3 was published on XX XXX 2023

Issue 3.2 was published on 10 May 2023

Issue 3.1 was published on 17th May 2019.

Issue 3.0 was published on 18th April 2019 following a public review period that closed on the 4th March 2019.

## **ABOUT WSAA**

The Water Services Association of Australia (WSAA) is the peak industry body representing the urban water industry. Our members provide water and sewerage services to over 24 million customers in Australia and New Zealand and many of Australia's largest industrial and commercial enterprises.

## **ACKNOWLEDGEMENT OF COUNTRY**

The Water Services Association of Australia acknowledges and pays respect to the past, present and future Traditional Custodians and Elders of this nation. We recognise their continuing connection to land and waters and thank them for protecting our waterways and environment since time immemorial.

## **DISCLAIMER**

This standard is issued by the Water Services Association of Australia Ltd and individual contributors are not responsible for the results of any action taken on the basis of information in this report, nor any errors or omissions. While every effort has been made to ensure the accuracy of that information, the Water Services Association of Australia (WSAA) does not make any claim, express or implied, regarding it.

## **COPYRIGHT**

© Water Services Association of Australia Ltd, 2023

## **ALL RIGHTS RESERVED**

This Standard is copyrighted. Apart from any use as permitted under the Copyright Act 1968, no part of this document may be reproduced or transmitted in any form or by any means, electronically or mechanical, for any purpose, without the express written permission of the Water Services Association of Australia Ltd.

For more information please contact [info@wsaa.asn.au](mailto:info@wsaa.asn.au)

## **PUBLICATION DETAILS**

Published by:

Water Services Association of Australia

Suite 802, Level 8

421 Docklands Drive

Docklands Vic 3008

ISBN No. 978-1-922808-13-4

Enquiries should be directed to [codes@wsaa.asn.au](mailto:codes@wsaa.asn.au).

Comments or suggestions for improvement to this standard should be forwarded to:

National Codes Manager

Water Services Association of Australia

Level 8, Suite 802,

401 Docklands Drive, Docklands VIC 3008, Australia or

[codes@wsaa.asn.au](mailto:codes@wsaa.asn.au).

Public Comment Draft

## PREFACE

---

This Standard was prepared by the Water Services Association of Australia (WSAA). It was published on the **XX XXX 2023** and incorporates WSA 137:2019 Amd 1, 2 and 3:2023.

The objective of this Standard is to provide material and performance requirements for manufacturers and purchasers of plastics maintenance shafts, maintenance chambers and maintenance holes for sewerage and sanitary drainage systems. Typically, a maintenance shaft, maintenance chamber or maintenance hole assembly comprises:

- (a) a base;
- (b) a vertical riser;
- (c) a cone, where required to reduce the opening at the top of a large diameter riser or placed immediately above the base to allow a smaller diameter riser to be used;
- (d) a sealed riser cap below, but close to the finished ground surface level.

The diameter range of the base and riser has been extended to DN 1000. Maintenance holes complying with this Standard can be supplied with or without steps or fixed ladders. This Standard does not provide detailed requirements for ladders or steps to facilitate person entry but appropriate EN Standards are referenced.

Other revisions include

- (i) loading testing on upper assembly components of maintenance shafts, maintenance chambers and maintenance holes
- (ii) provision of slip resistant raised surface patterns on maintenance hole benching and testing requirements.

NOTE: Maintenance shafts, maintenance chambers and maintenance holes complying with this Standard may also be suitable for other applications such as stormwater drainage.

In-service performance of a maintenance shaft, chamber or hole is strongly dependent on a supportive embedment. It should be recognised that it is extremely difficult to anticipate soil types, soil loadings and future soil movement in all possible locations and conditions. Specific types of embedment and backfill materials and compaction standards for various depths and soil types should be adopted in order to minimise the risk of long-term failure. Thus, even with compliance with these performance requirements, installation conditions will have a significant influence on the long-term performance of maintenance shafts, maintenance chambers and maintenance holes.

The design criteria of AS/NZS 2566.1, Buried flexible pipelines, Part 1: Structural design, provide guidance. Installation should be in accordance with design drawings and the Gravity Sewerage Code of Australia—WSA 02.

This Standard adopts the same means of determining structural integrity of maintenance shafts, maintenance chambers and maintenance holes and durability of materials as ISO 13272. The elastomeric seal joint requirements are similar to ISO 13272 except that the base-to-pipe and base-to-riser joints are required to additionally comply with interface pressure and contact width as specified in, for example, AS/NZS 1260 and the infiltration / exfiltration test pressures are higher.

The plastics materials covered by this Standard include PVC-U, PE, PP and PP-MD. This document recognises that materials demonstrated to comply with the requirements of some AS/NZS and ISO Standards are suitable for the manufacture of maintenance shaft risers and/or bases, provided the structural integrity and durability requirements are satisfied. Other PVC-U, PE, PP or PP-MD materials need to satisfy additional durability requirements in order to demonstrate suitability. Maintenance shaft, maintenance chamber and maintenance hole bases are typically manufactured by injection moulding, rotational moulding or fabrication.

Provided that installation, embedment support and operating conditions conform to the guidelines in this Standard, maintenance shaft, maintenance chamber and maintenance hole

life expectancy are expected to exceed 50 years<sup>1</sup>. A riser stiffness as low as SN4 may be considered, subject to and supported by structural analysis based on AS/NZS 2566.1. The structural analysis shall consider buckling stability of the riser in different soil types with a water table to full installation depth.

This Standard provides for an indicative accessibility test, using proving tools of two standard shapes. Notwithstanding this and for the purposes of product appraisal, the ease of ingress and egress of maintenance and condition assessment equipment – particularly at higher installation depths and for base configurations that involve smaller diameter vertical shafts and sewer connection diameters, “fit-for-purpose” accessibility should be demonstrated by means of installation trials, using the type of equipment that is routinely used by WSAA member utilities.

It is recognised that low surface energy acrylic structural adhesives may be used to joint dissimilar plastics such as PE and PVC in some maintenance shaft, chamber and hole products. Test requirements for PE to PVC joints using low surface energy acrylic structural adhesives are specified in WSA PS 287.

The Appendices are identified as ‘normative’ and, as such, form integral requirements of this Standard.

Where a WSAA ruling to this Standard is of public significance and has been authorised for issue, it will be available from the WSAA website [www.wsaa.asn.au](http://www.wsaa.asn.au). When the substance of a ruling has been included in an amended standard, the ruling will be withdrawn at the time of publication of the amendment.

---

<sup>1</sup> It should be noted, maintenance shafts, chambers or holes complying with this standard are often designed on the basis of 50 year extrapolated test data. This is established international practice but is not intended to imply the service life of maintenance shafts, chambers or holes is limited to 50 years. For correctly manufactured and installed structures, the actual life can not be predicted, but can logically be expected to be well in excess of 100 years before major rehabilitation is required.

<b>ACKNOWLEDGMENTS</b>	<b>2</b>
<b>PREFACE</b>	<b>4</b>
<b>1 SCOPE AND GENERAL</b>	<b>9</b>
1.1 SCOPE	9
1.2 COMPLIANCE REQUIREMENTS	9
1.3 LIMITATIONS	9
1.4 REFERENCED DOCUMENTS	11
1.5 DEFINITIONS	14
1.5.1 Average service temperature	14
1.5.2 Effective seal	14
1.5.3 Effective sealing length	14
1.5.4 Maintenance chamber	14
1.5.5 Maintenance shaft	14
1.5.6 Maintenance hole	15
1.5.7 Maintenance shaft, maintenance chamber and maintenance hole base	15
1.5.8 Riser	15
1.5.9 Cone	15
1.5.10 Cap	15
1.5.11 Telescopic part	15
1.5.12 Inlet connector	15
1.5.13 Installation Depth (H)	15
1.5.14 Maximum installation depth ( $H_{max}$ )	15
1.6 ABBREVIATIONS	16
<b>2 MATERIAL REQUIREMENTS</b>	<b>17</b>
2.1 GENERAL	17
2.2 MATERIALS	17
2.2.1 General	17
2.2.2 Materials for bases	17
2.2.3 Materials for risers and cones and inlet connectors	17
2.2.4 Rework	18
2.2.5 Elastomeric seals	18
2.2.6 Solvent cements and priming fluids	18
2.3 FREEDOM FROM DEFECTS	18
2.3.1 General	18
2.3.2 Pipe ends	19
2.3.3 Cleanliness	19
2.4 DIMENSIONS	19
2.4.1 Sockets and spigots	19
2.4.2 Effective sealing length	19
2.5 SURFACE PATTERNS ON MAINTENANCE HOLE BENCHING	19
2.5.1 Maintenance hole benching	19
2.6 PACKAGING, STORAGE, HANDLING AND TRANSPORTATION	19
<b>3 PERFORMANCE REQUIREMENTS</b>	<b>20</b>
3.1 GENERAL	20
3.2 STRUCTURAL INTEGRITY OF BASE	20
3.3 IMPACT RESISTANCE OF BASE	20
3.4 RING STIFFNESS OF RISER	20
3.5 HIGH TEMPERATURE STRESS RELIEF OF PVC-U COMPONENTS	20
3.6 ACCESSIBILITY TEST	21
3.7 ELASTOMERIC SEAL JOINTS	22
3.7.1 General	22
3.7.2 Water tightness of pipe joints between a pipe and the base of a maintenance shaft, maintenance chamber or maintenance hole	22

<b>3.7.3</b> Watertightness of the base to riser connection	22
<b>3.7.4</b> Watertightness of riser assembly components between riser and accompanying components	22
<b>3.7.5</b> Elastomeric joint seal effectiveness	22
3.8 INTEGRITY OF THE CAP AND SEAL	23
<b>3.8.1</b> General	23
<b>3.8.2</b> Liquid infiltration test	23
3.9 CHARACTERISATION OF ROTATIONALLY MOULDED PRODUCT SUBMITTED FOR PERFORMANCE TESTING	23
3.10 RISER AND RISER JOINT LOAD RESISTANCE	23
<b>3.10.1</b> General	23
<b>3.10.2</b> Type testing	23
3.11 NEAR SURFACE COMPONENTS	24
<b>3.11.1</b> General	24
<b>3.11.2</b> Load bearing resistance	24
3.12 MAINTENANCE HOLE STEPS	24
<b>3.12.1</b> Load bearing resistance	24
<b>3.12.2</b> Pull-out resistance	24
3.13 SLIP RESISTANCE	24
<b>4 MANUFACTURE</b>	<b>24</b>
4.1 DIMENSIONS OF THE BASE, CONE AND RISER	24
4.2 WELDING	24
<b>4.2.1</b> PVC	24
<b>4.2.2</b> PE and PP	25
<b>4.2.3</b> Training and certification	25
4.3 SOLVENT CEMENT JOINTING	25
4.4 MAINTENANCE HOLE STEPS AND LADDERS	25
<b>5 MARKING REQUIREMENTS</b>	<b>25</b>
5.1 GENERAL	25
5.2 ADDITIONAL INFORMATION	26
<b>APPENDIX A</b>	<b>27</b>
<b>MEANS OF DEMONSTRATING COMPLIANCE WITH THIS STANDARD</b>	<b>27</b>
A1 SCOPE	27
A2 RELEVANCE	27
A3 BATCH	27
A3.1 Acceptable quality level (AQL)	27
A3.2 Batch	27
A3.3 Batch release test	27
A3.4 Inspection level	27
A3.5 Lot	27
A3.6 New formulation	27
A3.7 Process verification test (PVT)	27
A3.8 Sample	28
A3.9 Sampling plan	28
A3.10 Type test (TT)	28
A4 PRODUCT CERTIFICATION	28
A5 MINIMUM SAMPLING AND TESTING FREQUENCY PLAN	28
A5.1 General	28
A5.2 Retesting	28
A5.3 Rejection after test	29
A6 NEW FORMULATION	34
A6.1 Material specification of PVC-U	34
A6.2 Material specification for PP and PP-MD	35

A6.3 Material specification for PE	35
<b>APPENDIX B</b>	<b>36</b>
<b>DURABILITY AND MATERIAL TESTING</b>	<b>36</b>
<b>(NORMATIVE)</b>	<b>36</b>
B1 SCOPE	36
B2 APPLICATION	36
B3 SAMPLES	36
B4 TEST PROCEDURE	36
B5 NON-STANDARD MATERIAL CHARACTERISTICS	36
<b>APPENDIX C</b>	<b>38</b>
<b>STRUCTURAL INTEGRITY OF BASE</b>	<b>38</b>
C1 GENERAL	38
C2 TEST PROCEDURE	38
C3 EVALUATION OF DATA	38
<b>APPENDIX D</b>	<b>39</b>
<b>METHOD FOR LOAD TESTING</b>	<b>39</b>
D1 SCOPE AND GENERAL	39
D1.1 Scope	39
D1.2 Relevance of test	39
D1.3 Preparation of test assemblies	39
D2 TEST PROCEDURE - LOAD TESTING	39
D2.1 Principle	39
D2.2 Apparatus	39
D2.3 Procedure	39
D3 TEST PROCEDURE - VACUUM	40
D3.1 Principle	40
D3.2 Apparatus	40
D3.3 Procedure for vacuum test	40
D4 TEST REPORT	40
<b>APPENDIX E</b>	<b>42</b>
<b>IMPACT RESISTANCE OF BASE</b>	<b>42</b>
<b>(NORMATIVE)</b>	<b>42</b>
E1 TEST EQUIPMENT	42
E2 RELEVANCE OF TEST	42
E3 TEST PROCEDURE	42
E4 TEST REPORT	42



## 1 SCOPE AND GENERAL

### 1.1 SCOPE

This Standard specifies the material, performance and design requirements for plastics maintenance shafts, maintenance chambers and maintenance holes comprising an injection moulded, rotationally moulded or fabricated base and riser made of unplasticised polyvinylchloride (PVC-U), polyethylene (PE), polypropylene (PP) or polypropylene with mineral modifiers (PP-MD).

A maintenance shaft, maintenance chamber or maintenance hole can be a one-piece construction or an assembly of different components manufactured from compatible materials.

The jointing of individual components may be achieved using:

- (a) elastomeric ring seal joints;
- (b) solvent cement joints for PVC-U;
- (c) welded joints for PVC-U, PP, PP-MD and PE;
- (d) extrusion welding;
- (e) mechanical jointing;
- (f) structural adhesive for joining PE and PVC.

Maintenance shafts, maintenance chambers and maintenance holes comprise a base and riser. They may also include:

- (i) a cone between the base and riser, or between the riser and cap, or on top of the riser;
- (ii) a telescopic part;
- (iii) other near-surface components.
- (iv) an inlet connector that is inserted into or fixed to the riser or forms part of the riser to provide for one or more pipe connections to the riser itself.

All maintenance shafts, maintenance chambers and maintenance holes complying with this Standard are:

- (A) intended to operate at atmospheric pressure and sewage temperature not greater than 40°C;
- (B) intended to be suitable for a maximum installation depth up to 6 m.<sup>2</sup>
- (C) not intended to bear vertical traffic loads directly,
- (D) intended for installation where vehicular traffic loads are transferred to the surrounding embedment, but not to the riser/ cone assembly beneath.

### 1.2 COMPLIANCE REQUIREMENTS

Methods for demonstrating compliance with this Standard shall be in accordance with [Appendix A](#).

### 1.3 LIMITATIONS

This Standard does not cover the use of maintenance shafts, maintenance chambers and maintenance holes intended at pressures other than atmospheric pressure nor the imposition of superimposed loads e.g. due to seismic events nor exposure to an average service temperature in excess of 35°C. Such special conditions shall be provided for by maintenance shaft, maintenance chamber and maintenance hole designers and the design performance shall be subjected to compliance testing.

---

<sup>2</sup> The maximum water table height is recommended by the manufacturer.

It should be recognised that it is extremely difficult to anticipate soil types, soil loadings and future soil movement in all possible locations and conditions. Specific types of embedment and backfill materials and compaction standards for various depths and soil types should be adopted in-order to minimise the risk of long term failure.

In-service performance of a maintenance shaft, chambers and holes is strongly dependent on a supportive embedment. The design criteria of AS/NZS 2566.1 provides guidance. Installation should be in accordance with WSA 02.

It should also be recognised that maintenance shafts, chambers and holes without moulded or integrally formed channels where appropriate, may necessitate hydraulic testing, to determine if additional hydraulic design criteria is required.

WSA TN 13 specifies the hydraulic and test plan requirements for assessing the suitability of manufactured maintenance structure bases (without formed channels) for installation in reticulation sewers. A reticulation sewer is generally DN 150 to DN 300

Maintenance hole bases meeting the requirements of WSA 02:2014 do not need to undergo any hydraulic performance assessments where formed channels are present.

Where a hydraulic performance assessment of maintenance structures needs to be undertaken it is recommended that the test plan restricts the number of tests to a manageable number.

## 1.4 REFERENCED DOCUMENTS

The following documents are referred to in this Standard:

### AS

- 681.1 Elastomeric seals – Material requirements for pipe joint seals used in water and drainage applications – Vulcanized rubber
- 681.2 Elastomeric seals – Material requirements for pipe joint seals used in water and drainage applications – Thermoplastic elastomers
- 1199 Sampling procedures for inspection by attributes
- 1199.1 Part 1: Sampling schemes indexed by acceptance quality limit (AQL) for lot-by-lot inspection
- 1646 Elastomeric seals for waterworks purposes
- 3996 Access covers and grates
- 4586 Slip resistance classification of new pedestrian surface materials

### AS/NZS

- 1260 PVC-U pipes and fittings for drain, waste and vent application
- 1462.1 Methods of test for plastics pipes and fittings Method 1: Method for determining the dimensions of pipes and fittings
- 1462.8 Methods of test for plastics pipes and fittings Method 8. Method for testing the leak tightness of assemblies
- 1462.11 Methods of test for plastics pipes and fittings Method 11. Method for high temperature stress relief testing of fittings
- 1462.13 Methods of test for plastics pipes and fittings Method 13. Method for the determination of elastomeric seal joint contact width and pressure
- 1462.22 Methods of test for plastics pipes and fittings Method 22. Method for the determination of pipe stiffness
- 1462.28 Methods of test for plastics pipes and fittings Method 28. Method for the assessment of the degree of pigment or carbon black dispersion in polyolefin pipes, fittings and compounds
- 1477 PVC pipes and fittings for pressure applications
- 2032 Installation of PVC pipe systems
- 2566.1 Buried flexible pipelines Part 1: Structural
- 2566.2 Buried flexible pipelines Part 2: Installation
- 3879 Solvent cements and priming fluids for PVC (PVC-U and PVC-M) and ABS and ASA pipes and fittings
- 4131 Polyethylene (PE) compounds for pressure pipes and fittings
- 4441 Oriented PVC (PVC-O) pipes for pressure applications
- 4765 Modified PVC (PVC-M) pipes for pressure applications
- 5065 Polyethylene and polypropylene pipes and fittings for drainage and sewerage applications

### EN

- 13101 Steps for underground man entry chambers. Requirements marking, testing and evaluation of conformity.
- 14396 Fixed ladders for manholes.
- 14758-1 Plastics piping systems for non-pressure underground drainage and sewerage – Polypropylene with mineral modifiers (PP – MD) – Part 1: Specifications for pipes, fittings and the system

### ISO

- 1133 Plastics – Determination of The Melt Mass-Flow Rate (MFR) and the Melt Volume-Flow Rate (MVR) of Thermoplastics

3127	Thermoplastics pipes – Determination of resistance to external blows – Round-the-clock method
3951.1	Sampling procedures for inspection by variables – Part 1: Specification for single sampling plans indexed by acceptance quality limit (AQL) for lot-by-lot inspection for a single quality characteristic and a single AQL
3951.2	Sampling procedures for inspection by variables – Part 2: General specification for single sampling plans indexed by acceptance quality limit (AQL) for lot-by-lot inspection of independent quality characteristics
3951.3	Sampling procedures for inspection by variables – Part 3: Double sampling schemes indexed by acceptance quality limit (AQL) for lot-by-lot inspection
3951.5	Sampling procedures for inspection by variables – Part 5: Sequential sampling plans indexed by acceptance quality limit (AQL) for inspection by variables (known standard deviation)
4427	Plastics piping systems — Polyethylene (PE) pipes and fittings for water supply
4435	Plastics piping systems for non-pressure underground drainage and sewerage – Unplasticised poly(vinyl chloride) (PVC-U)
8772	Plastics piping systems for non-pressure underground drainage and sewerage – Polyethylene (PE)
8773	Plastics piping systems for non-pressure underground drainage and sewerage – Polypropylene (PP)
13229	Thermoplastics piping systems for non-pressure applications – Unplasticized poly(vinyl chloride) (PVC-U) pipes and fittings – Determination of the viscosity number and K-value
13259	Thermoplastics piping systems for underground non-pressure applications – Test method for leaktightness of elastomeric sealing ring type joints
13266	Thermoplastics piping systems for non-pressure underground drainage and sewerage -- Thermoplastics shafts or risers for inspection chambers and manholes -- Determination of resistance against surface and traffic loading
13267	Thermoplastics piping systems for non-pressure underground drainage and sewerage — Thermoplastics inspection chamber and manhole bases — Test methods for buckling resistance
13272	Plastics piping systems for non-pressure underground drainage and sewerage – Unplasticised poly(vinyl chloride) (PVC-U), polypropylene (PP), polypropylene with mineral modifiers (PP-MD) and polyethylene (PE) – Specifications for manholes and inspection chambers in traffic areas and underground installations
21138-1	Plastics piping systems for non-pressure underground drainage and sewerage – Structured-wall piping systems of unplasticised poly(vinyl chloride) (PVC-U), polypropylene (PP) and polyethylene (PE) – Part 1: Material specifications and performance criteria for pipes, fittings and system
21138-2	Plastics piping systems for non-pressure underground drainage and sewerage – Structured-wall piping systems of unplasticised poly(vinyl chloride) (PVC-U), polypropylene (PP) and polyethylene (PE) – Part 2: Pipes and fittings with smooth external surface, Type A
21138-3	Plastics piping systems for non-pressure underground drainage and sewerage – Structured-wall piping systems of unplasticised poly(vinyl chloride) (PVC-U), polypropylene (PP) and polyethylene (PE) – Part 3: Pipes and fittings with non-smooth external surface, Type B
<b>ISO/IEC</b> Guide 28	Conformity assessment – Guidance on a third party certification system for products

**WSAA**

WSA 01 Polyethylene Code of Australia

WSA 02 Gravity Sewerage Code of Australia

WSA TN 13 Information and Guidance Note for the Hydraulic Performance of  
Manufactured Maintenance Structure Bases.

Public Comment Draft

## 1.5 DEFINITIONS

### 1.5.1 Average service temperature

The average of sustained service temperatures ( $T_m$ ) that a maintenance shaft, maintenance chamber or maintenance hole is exposed to during service can be calculated from the following equation:

$$T_m = \frac{2T_{sew} + T_{soil}}{3}$$

where

$$T_{sew} = \text{average sewage temperature assessed over summer and winter months} \\ = 0.5T_{sew\text{-summer}} + 0.5T_{sew\text{-winter}}$$

$$T_{soil} = \text{average soil temperature assessed over summer and winter months} \\ = 0.5T_{soil\text{-summer}} + 0.5T_{soil\text{-winter}}$$

The average temperature for the sewage and soil in contact with the maintenance shaft, maintenance chamber or maintenance hole is the weighted average of the temperatures, as assessed in proportion to the time spent at each temperature during a given period under operational conditions.

NOTE: For practical purposes, this should be taken to be the average of temperatures to which a maintenance shaft, maintenance chamber or maintenance hole may be exposed internally and externally during the summer and winter of a typical operational year, which may be taken to be two equal 6 monthly periods. For non-wastewater applications,  $T_{sew}$  may be taken as the average seasonal temperature assessed for the particular fluids involved.

NOTE Temperature is expressed in degree Celsius (°C)

### 1.5.2 Effective seal

That part of the interface between an elastomeric seal and the spigot and socket where the contact pressure is greater than 0.4 MPa for vulcanised seals and 0.47 MPa for thermoplastic seals.

### 1.5.3 Effective sealing length

#### 1.5.3.1 Socket-mounted seals

The distance between the cross-sectional centre of the elastomeric sealing ring installed in the socket and the root of the socket.

#### 1.5.3.2 Spigot-mounted seals

The distance from the position of effective seal of the elastomeric sealing ring to the mouth of a socket or the point at which the mouth of a socket flares.

### 1.5.4 Maintenance chamber

Structure with a moulded and channelled or spherical base with up to three inlets  $\leq$ DN 300 or one DN 375 inlet in the straight 180° profile at the base, a riser of size DN 600 – DN 800 and a removable cover constructed on a sewer that allows limited change of grade and/or direction and provides access to the sewer for inspection and most maintenance equipment from the surface. Base configurations may include in-line, bend or junction.

### 1.5.5 Maintenance shaft

Structure with a moulded and channelled or spherical base with up to three inlets  $\leq$ DN 250, a riser of size DN 225 – DN 450 and a removable cover constructed on a sewer that allows limited change of grade and/or direction and provides access to the sewer for inspection and some maintenance equipment from the surface. Base configurations may include in-line, bend, junction or terminating. A maintenance shaft at the end of a reticulation sewer is known as a terminal maintenance shaft.

### 1.5.6 Maintenance hole

Structure with a formed channel base, benching with up to three inlets  $\leq$  DN 375 at the base, a riser having an internal diameter not less than DN 1000, an adaptor providing an entry diameter  $\geq$  600 mm and a removable cover constructed on a sewer that allows limited change of grade and/or direction and provides access to the sewer for inspection and maintenance equipment, which may include permitted entry of a person.

NOTE: Alternative base design without formed channel may be considered subject to hydraulic assessment of the flow properties. Refer to WSA TN 13.

### 1.5.7 Maintenance shaft, maintenance chamber and maintenance hole base

Base part of a maintenance shaft, maintenance chamber or maintenance hole, allowing direct connection to buried sewer pipes and including formed channels with benching, as appropriate.

### 1.5.8 Riser

A component, usually circular in cross-section, that provides service access to the base component from ground surface level. A riser may be an integral component of the maintenance shaft, maintenance chamber or maintenance hole assembly or a separate circular shaft that is securely jointed to the base.

NOTES:

1. The primary maintenance shaft, maintenance chamber and maintenance hole structure, typically, terminates at a level close to but beneath finished surface level. A suitably designed access cover, frame (and concrete surround where specified) duly supported by installed embedment in accordance with WSA 02 requirements is typically provided above this level.
2. The internal diameter of the riser shall be used to classify the nominal size of maintenance shaft, maintenance chambers or maintenance hole. Risers can also be measured based on their outside diameter, in which case Manufacturers may elect to nominate the OD of the riser, as the nominal size for the purposes of classification.

### 1.5.9 Cone

A tapered adaptor placed at the top of a riser to reduce the diameter of the primary riser, chamber or base to a smaller riser diameter.

### 1.5.10 Cap

A removable component attached to the top of a maintenance shaft or maintenance chamber riser to prevent infiltration of ground or surface water and for the purposes of routine operational and maintenance activities and equipment.

NOTE: Caps can be either a locking type or a type that will permit flow relief.

### 1.5.11 Telescopic part

Part of a shaft or chamber assembly that accommodates differential settlement or movement after installation and allows appropriate re-adjustment of riser, cone and cap height.

### 1.5.12 Inlet connector

A component that allows single or multiple conveyance pipes to be connected to a riser. An inlet connector may form an integral part of a riser or it may be mechanically jointed to a riser wall.

NOTE: Inlet connectors may be installed before, during or after construction.

### 1.5.13 Installation Depth ( $H$ )

Depth from finished surface level to pipe invert level.

### 1.5.14 Maximum installation depth ( $H_{max}$ )

The installation depth nominated by the manufacturer, within the depth constraints of Clause 1.1.

**1.6 ABBREVIATIONS**

%	percentage
°C	degree Celsius
AQL	acceptable quality level
AS	Australian Standard
AS/NZS	Australia and New Zealand Standard
DN	nominal size
G	gravitational constant
H	hour
HALS	hindered amine light stabiliser
IEC	International Electrotechnical Commission
ISO	International Standards Organisation
JAS-ANZ	Joint Accreditation System of Australia and New Zealand
kg	kilogram
kN	kilonewton
kPa	kilopascal
M	metre
MFR	melt mass-flow rate
mm	millimetre
min	minute
MPa	megapascal
N	Newton
N/m/m	Newtons per metre per metre
PE	polyethylene
PP	polypropylene
PP-MD	polypropylene with mineral modifiers
PVC	polyvinylchloride
PVC-U	Poly(vinyl chloride) unplasticised
PVT	process verification test
R	rating factor for the durability test
TT	type test
WSAA	Water Services Association of Australia



## 2 MATERIAL REQUIREMENTS

### 2.1 GENERAL

This section specifies minimum performance requirements for PVC-U, PE, PP and PP-MD maintenance shaft, maintenance chamber, maintenance hole, elastomeric seals and solvent cement components. It also specifies requirements for finished product freedom from defects, packaging, storage and transport.

NOTE: Different components of maintenance shaft, maintenance chamber and maintenance hole assemblies may be manufactured from one or more of the base polymeric materials covered by the scope of this standard.

### 2.2 MATERIALS

#### 2.2.1 General

Additives containing compounds based on lead (Pb), cadmium (Cd) or mercury (Hg) shall not be used in the manufacture of any components. Recycled PVC-U material containing these compounds may be used in the core of a sandwich construction PVC-U riser.

#### 2.2.2 Materials for bases

##### 2.2.2.1 Standard materials

When a material satisfying the material requirements of one of the Standards listed in [Table 2.1](#) is used for manufacturing bases for maintenance shafts maintenance chambers or maintenance holes it shall, in addition, exhibit no cracks when tested for 1,000 h in accordance with [Appendix B](#) using the buckling resistance test specified in ISO 13267. The durability test shall be performed at a negative internal pressure of  $-\frac{10H_{max}}{R}$  kPa and at the appropriate temperature given in [Table B1](#) of Appendix B.

Note: *R* is the rating factor listed in [Table B1](#) for PVC-U, PE, PP and PP-MD.

##### 2.2.2.2 Non-standard materials

When a material other than that complying with the material requirements of the Standards listed in [Table 2.1](#) is proposed for use in bases for maintenance shafts, maintenance chambers or maintenance hole, it shall, for acceptance, exhibit no cracks when tested for 3,000 h in the buckling resistance test specified in ISO 13267. The durability test shall be performed at a negative internal pressure of  $-\frac{10H_{max}}{R}$  kPa and at the appropriate temperature given in [Table B1](#) of Appendix B. Non-standard materials shall also be characterised and tested in accordance with [Clause B5](#) of Appendix B.

#### 2.2.3 Materials for risers and cones and inlet connectors

##### 2.2.3.1 Standard materials

Materials complying with the Standards listed in [Table 2.1](#) or complying with [Clause 2.2.2.2](#) that may be used for manufacturing risers, cones and inlet connectors without additional material requirements. Pipes complying with the requirements of AS/NZS 1477, AS/NZS 4441 or AS/NZS 4765 for an appropriate stiffness rating may also be used as riser components.

##### 2.2.3.2 Non-standard materials

When a material not complying with either [Table 2.1](#) or [Clause 2.2.2.2](#) is used to manufacture risers, the material shall comply with [Clause B5 of Appendix B](#).

##### 2.2.3.3 Elastomeric Components

Elastomeric components forming part of an inlet connector shall comply with AS 1646 and AS EN 681.1 or AS EN 681.2.

**TABLE 2.1**  
**STANDARD MATERIALS**

<b>Material</b>	<b>Standard</b>
PVC-U	AS/NZS 1260, ISO 4435, ISO 21138.1, ISO 21138.2, ISO 21138.3,
PE	AS/NZS 4131, AS/NZS 5065, ISO 4427, ISO 8772, ISO 21138.1, ISO 21138.2, ISO 21138.3. A coloured or natural material that is: <ul style="list-style-type: none"> <li>• fully pre-compounded</li> <li>• produced from a base resin used to produce a compound complying with AS/NZS 4131</li> <li>• contains a minimum of 0.2% of a hindered amine light stabiliser (HALS)</li> <li>• has additives evenly dispersed, having a rating of appearance of not worse than Micrograph B in Annex B of AS/NZS 1462.28 and the arithmetic average of the maximum sizes of pigment agglomerations or foreign bodies shall not exceed 60 µm (corresponding to Grade 3 of AS/NZS 1462.28</li> <li>• has an MFR, when measured in accordance with ISO 1133 Condition T, not greater than 2.0</li> </ul>
PP	AS/NZS 5065, ISO 8773, ISO 21138.1, ISO 21138.2, ISO 21138.3
PP-MD	EN 14758-1

#### **2.2.4 Rework**

Clean rework material, which is generated from the manufacturer's own production of maintenance shaft, maintenance chamber and maintenance hole components in accordance with this Standard, may be used provided that it is derived from the same material as that used in compliant product manufacture.

When rework material is added to a production run, the manufacturer shall treat this run as a new batch. For new batches of rotational moulding materials, the oxidation induction time and MFR shall be re-characterised in accordance with [Clause B5](#) of Appendix B.

#### **2.2.5 Elastomeric seals**

Elastomeric seals shall comply with AS 1646 and AS 681.1 or AS 681.2.

#### **2.2.6 Solvent cements and priming fluids**

Solvent cements and priming fluids used for jointing PVC-U assemblies shall comply with AS/NZS 3879.

#### **2.2.7 Materials**

Structural adhesives shall comply with the requirements of Appendix F and WSA PS 287. Structural adhesive joints shall be formed within a controlled environment. They shall not be prepared in the field.

### **2.3 FREEDOM FROM DEFECTS**

#### **2.3.1 General**

When viewed without magnification, the finished internal and external surfaces of maintenance shaft, chamber and hole components shall be smooth, clean and free from defects likely to impair conformity with this Standard. Components shall not have any blisters, voids, burnt particles or heat marks. Where grooves, wrinkles, rippling, dents or projections are present, the components shall comply with the specified dimensional requirements. Where defects are present and the product is submitted for acceptance, the manufacturer shall be able to demonstrate conformance to this Standard.

NOTE: Some products have grooves intentionally moulded into the surfaces of components for hydraulic reasons, which should not be cause for rejection.

### **2.3.2** *Pipe ends*

Pipe ends or spigots on maintenance shafts, maintenance chambers and maintenance hole shall be cleanly cut square with the axis of the ends of the component and within any cutting zone in accordance with the pipe manufacturers recommendations.

### **2.3.3** *Cleanliness*

Maintenance shaft, maintenance chamber and maintenance hole components shall be internally clean and free from swarf and other manufacturing debris.

NOTE: The defects described in Clauses 2.3.1, 2.3.2 and 2.3.3 cannot be completely quantified. Where the presence, size or frequency of any such defects are considered to be of concern, appropriate arrangements for product acceptability (or not) should be made between the purchaser/approving authority/conformance assessment body (as appropriate), and the manufacturer. This may be achieved by the provision of acceptable type samples or repair/replacement alternatives.

## **2.4 DIMENSIONS**

### **2.4.1** *Sockets and spigots*

The dimensions of socketed and spigoted maintenance shafts, maintenance chambers and maintenance hole components shall be wholly compatible with the product Standard for the pipes to which they are intended to be connected.

### **2.4.2** *Effective sealing length*

The effective sealing length of a socketed or spigoted (pipe) connection component designed for elastomeric seal jointing, when measured in accordance with AS/NZS 1462.1 shall be not less than the value specified in the relevant pipe product Standard. Where that Standard specifies a length of engagement rather than an effective sealing length, the length of connection engagement, when measured in accordance with AS/NZS 1462.1, shall be not less than the length of engagement specified.

## **2.5 SURFACE PATTERNS ON MAINTENANCE HOLE BENCHING**

### **2.5.1** *Maintenance hole benching*

The surface pattern shall be designed so that it does not collect sewage. The surface pattern shall have a slip-resistant raised pattern and be in accordance with the test requirements in Appendix D and E of AS 4586.

Slip resistant and displacement space of the benching shall satisfy the test requirements of Clause 3.13.

## **2.6 PACKAGING, STORAGE, HANDLING AND TRANSPORTATION**

Maintenance shaft, maintenance chamber and maintenance hole components and assembled components shall be transported, handled and stored in accordance with the manufacturer's recommendations in a manner that prevents damage, deterioration or excessive distortion.

Finished assemblies or the separate components of an assembly may be transported to site separately for installation or for assembly and installation respectively.

Maintenance shafts, maintenance chambers, maintenance holes components and assembled components shall be stacked in a manner that minimises ovalisation and protects ends, seals and projections from damage due to handling and installation impacts and superimposed loads.

Maintenance shaft, maintenance chamber or maintenance hole components and assembled components shall not be stored near motors, generators or other heat-emitting equipment.

Maintenance shaft, maintenance chamber or maintenance hole components and assembled components made of the following materials may tolerate exposure to direct sunlight for up to 2 years:

- PVC-U that contains  $\geq 1.5$  parts of rutile titanium dioxide (TiO<sub>2</sub>) pigment per 100 parts by mass of PVC content;
- PE, PP or PP-MD containing 2.0 to 2.5% of carbon black in accordance with AS/NZS 4131 or AS/NZS 5065;
- PE or PP containing  $\geq 0.2\%$  HALS in accordance with AS/NZS 4131 or AS/NZS 5065.

Maintenance shaft, maintenance chamber and maintenance hole components and assembled components of other materials shall not be exposed to direct sunlight.

If extended exposure to direct sun for extended periods is anticipated, maintenance shaft chamber and hole assemblies and components shall be stored under cover in a manner that facilitates all round ventilation and air movement and that prevents heat entrapment.

### 3 PERFORMANCE REQUIREMENTS

#### 3.1 GENERAL

This section specifies the performance requirements applicable to maintenance shafts, maintenance chamber and maintenance hole assemblies and components for installation depths up to 6 m. Maintenance shaft, chamber and hole assemblies shall be designed to be structurally sound and wholly resistant to buoyancy uplift by acceptable (nominated) margins of safety for all burial depths up to 6 m and for all water table levels up to finished surface level.

#### 3.2 STRUCTURAL INTEGRITY OF BASE

When tested for not less than 1,000 h at 20 to 25°C and negative internal pressure of  $-10H + 0.5, -0$  kPa in accordance with [Appendix C](#) and ISO 13267, the base shall not collapse nor show any signs of cracking. The predicted 50 year vertical H deformations shall be  $\leq 5\%$  of the main sewer pipe outside diameter. The predicted 50 year horizontal W deformation shall be  $\leq 10\%$  of the main sewer outside diameter.

#### 3.3 IMPACT RESISTANCE OF BASE

When tested at  $23 \pm 2^\circ\text{C}$  in accordance with [Appendix E](#) using a striker of  $1,000 + 10, -0$  g mass having a radius of 50 mm and a drop height of  $2500 + 25 - 0$  mm the base shall not exhibit any cracks or other damage that impairs the function of the base.

#### 3.4 RING STIFFNESS OF RISER

When tested in accordance with AS/NZS 1462.22 the ring stiffness of the riser shall be  $\geq 4,000$  N/m/m (SN4).

#### 3.5 HIGH TEMPERATURE STRESS RELIEF OF PVC-U COMPONENTS

When tested at a temperature of  $150 \pm 4^\circ\text{C}$  for 30 +3, -0 min in accordance with AS/NZS 1462.11, PVC-U injection moulded components shall comply with the following requirements:

- (a) There shall be no evidence of inclusions or voids of size greater than 20% of the wall thickness up to a maximum of 1 mm.
- (b) Delamination or damage at the injection point shall not have reduced the wall thickness to less than 50% of the nominated minimum wall thickness.
- (c) The weld line shall not open up to a depth of more than 50% of the wall thickness.

NOTE: The weld line is likely to become prominent and the fitting distorted, but this does not constitute failure.

- (d) Not more than 5% of the total internal and external surface area of the chamber shall exhibit blisters and/or surface delamination.

**3.6 ACCESSIBILITY TEST**

A maintenance shaft, maintenance chamber or maintenance hole shall be assembled with a 1 m length of riser pipe in a vertical position and with 1 m lengths of sewer pipe connected to each sewer pipe connection port. A proving tool of standard shape A, with dimensions as shown in Table 3.1 and Figure 3.1, shall be attached to cables and inserted through the riser pipe and pulled out through each of the sewer pipe connections in turn. This procedure shall also be repeated for a proving tool of standard cylindrical shape B, with dimensions as shown in Table 3.1.

The standard shapes A and B shall be capable of insertion with diameter  $D_1$  as the leading edge and shall pass, without restriction, through all of the connection ports of the maintenance shaft, maintenance chamber or maintenance hole and into the connecting sewer pipes using a pulling force not exceeding 250 N.

The standard shapes shall be manufactured from steel or aluminium alloy with all sharp edges removed.

**TABLE 3.1  
DIMENSIONS OF STANDARD PROFILES**

Inlet-outlet sewer nominal size <sup>1</sup> DN	Standard Shape A (see figure 3.1)			Standard shape B	
	Length, $L$	Diameter $D_1$	Diameter $D_2$	Length, $L$	Diameter $D_1$
100 / 110	300	90	65	400	75
150 / 160	400	135	90	400	125
175 / 200	400	170	100	500	125
225 / 250	500	210	120	500	125
300 / 315	500	270	120	500	125
375 / 400	500	270	120	500	125

NOTE:

- 1. In accordance with the appropriate product Standard. Refer also to Clause 3.1 NOTE for considerations that may apply to the suitability of maintenance shafts for connection to smaller (> DN 225) pipes.

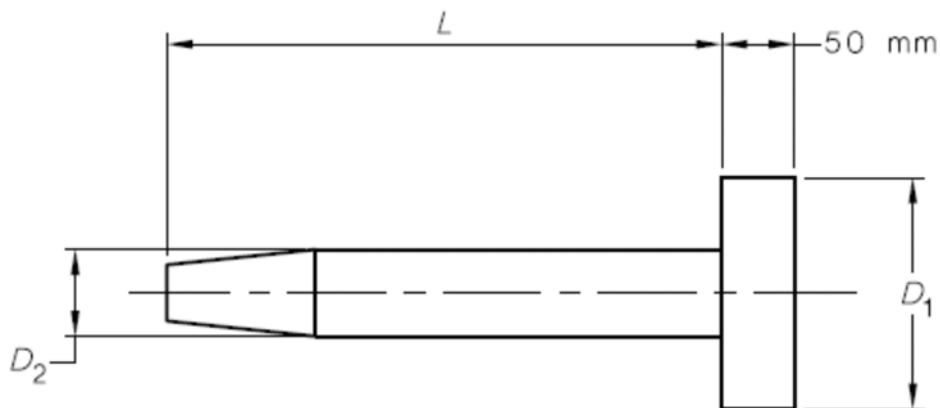

### FIGURE 3.1 STANDARD SHAPE A

NOTE: This shape is indicative of a range of utility maintenance and condition assessment equipment (CCTV tractors and jet washers) but may not fully replicate accessibility to some modern automated equipment that is connected to a truck mounted viewing console by a semi-flexible multi-functional 'umbilical' conduit containing electrical and signal cables and hydraulic power hoses. Accessibility can be further impaired where base/riser are vertical and small in diameter, where inlet connector diameters are also small (< DN 225) and where installation depth presents higher risks of equipment damage or loss. Demonstration of accessibility fitness-for-purpose accessibility may require specific installation trials that use the type of utility equipment described above. Alternate profile shapes may alternatively be nominated and tested by agreement between the manufacturer and asset owner.

## 3.7 ELASTOMERIC SEAL JOINTS

### 3.7.1 General

Elastomeric seal joints for joining base to pipes or to risers shall comply with the following requirements for hydrostatic pressure, liquid infiltration and contact width and pressure.

### 3.7.2 Water tightness of pipe joints between a pipe and the base of a maintenance shaft, maintenance chamber or maintenance hole

When tested in accordance with ISO 13259, Condition D, and configured as shown in Table 3.2, the joints shall not leak during the internal positive pressure tests and the pressure shall remain at least 3 kPa greater than the negative test pressure during the negative pressure test.

### 3.7.3 Watertightness of the base to riser connection

When tested in accordance with ISO 13259, Condition A, and configured as shown in Table 3.2, the joints shall not leak during the internal positive pressure tests and the pressure shall remain at least 3kPa greater than the negative test pressure during the negative pressure test under the following conditions, the joints shall not leak.

**TABLE 3.2**  
**WATER TIGHTNESS TEST CONFIGURATIONS**

Test Configuration	Pipe to base	Base to riser
Test temperature	23 ± 5°C	23 ± 5°C
Pipe diametral deflection	≥10%	N/A
Joint socket deflection	≥5%	N/A
Joint angular deflection	2 -0, +0.2° for DN ≤315 1.5-0, +0.2° for 315 <DN ≤630 1 -0, +0.2° for DN >630.	N/A
Low positive test pressure	5.0 + 0.5 - 0 kPa	5.0 ± 0.25 - 0 kPa
High positive test pressure	[(H <sub>Max</sub> + 10)] ± 2 kPa	[(H <sub>Max</sub> + 10)] ± 2 kPa
Negative test pressure	[(H <sub>Max</sub> - 10)] ± 2 kPa	[(H <sub>Max</sub> - 10)] ± 2 kPa

### 3.7.4 Watertightness of riser assembly components between riser and accompanying components

Maintenance shaft, chamber and hole assemblies, including telescopic riser sections, riser cones and riser inlet pipe connectors, where incorporated into the assemblies, shall sustain watertightness testing for 15 +5, -0 minutes by the application of a test pressure of [(H<sub>Max</sub> + 10)] ± 2 kPa without leakage.

### 3.7.5 Elastomeric joint seal effectiveness

This requirement applies to all elastomeric seal joints between shaft and chamber components (e.g. base to riser body and base to inlet connectors).

When determined in accordance with AS/NZS 1462.13, elastomeric seals manufactured to:

- (a) AS 1646 and AS 681.1 shall have a contact pressure  $\geq 0.4$  MPa over a continuous width of  $\geq 4$  mm.
- (b) AS 1646 and AS 681.2 shall have a contact pressure  $\geq 0.47$  MPa over a continuous width of  $\geq 4$  mm.

### 3.8 INTEGRITY OF THE CAP AND SEAL

#### 3.8.1 General

The assembly used to close the top of the riser shall comply with liquid infiltration requirements. The assembly shall be prepared for testing in the same configuration as proposed for field installation.

#### 3.8.2 Liquid infiltration test

When tested in accordance with AS/NZS 1462.8, but without angular deflection or diametric distortion, the assembly shall not leak, when subjected to an internal vacuum corresponding to a gauge pressure of  $-50$  to  $-55$  kPa for 60 +5, -0 min.

### 3.9 CHARACTERISATION OF ROTATIONALLY MOULDED PRODUCT SUBMITTED FOR PERFORMANCE TESTING

The initial product weight of rotationally moulded products, prior to any machining and/or installation of fittings, submitted for performance testing according to this Standard, shall be determined before the testing is performed. The individual item weight of subsequent production shall be maintained to within the limits shown in [Table 3.3](#).

**TABLE 3.3**  
**CHARACTERISATION OF ROTATIONALLY MOULDED PRODUCTS**

Initial product weight kg	Subsequent production %
< 10	> 96
$\geq 10 \leq 50$	> 97
> 50	> 98

### 3.10 RISER AND RISER

#### 3.10.1 General

Riser and riser joint(s) shall be designed to withstand typical mechanical impact and frictional down-drag forces generated by embedment surround and backfill installation procedures and by subsequent post-installation movement by demonstrating the stability of joint seal integrity and disposition.

A design shall be considered adequate for this purpose where it incorporates a telescopic riser or an elastomeric seal jointed system that demonstrates acceptable joint movement tolerances (e.g. > 30 mm) and resistance to movement.

Alternatively, joint design shall be verified by type testing in accordance with Clause 3.10.2.

#### 3.10.2 Type testing

When loaded in accordance with [Appendix D](#), then subjected to an internal vacuum, an assembled maintenance shaft, maintenance chamber or maintenance hole shall not display any sign of buckling and no joints shall display any evidence of leaking.

Changes in external dimensions shall not exceed the following:

- (a) 4% when measured through and at right angles to the centroid of the shaft, chamber or maintenance hole and the riser.

- (b)  $\pm 5$  mm from a straight line or a flat plane along the invert of the shaft, chamber or maintenance hole.

### 3.11 NEAR SURFACE COMPONENTS

#### 3.11.1 General

Upper assembly components of maintenance shafts, maintenance chambers and maintenance holes shall be designed to withstand surface and traffic loading.

Note Upper assembly components may include riser, cone and telescopic joints.

#### 3.11.2 Load bearing resistance

When subjected to load test in accordance with ISO 13266 the upper assembly components should not exhibit any cracks, collapse or other similar form of structural failure likely to impair performance.

The classification of application shall be in accordance with AS 3996.

Note The maximum load is not to be confused with the test loads in AS 3996.

### 3.12 MAINTENANCE HOLE STEPS

#### 3.12.1 Load bearing resistance

When tested in accordance with EN 13101 with a vertical load of 2 kN the deformation of steps under load shall be  $\leq 10$  mm and the residual deformation shall be  $\leq 5$  mm.

#### 3.12.2 Pull-out resistance

When tested in accordance with EN 13101 with a horizontal force of 1 kN there shall be no pull-out of the steps.

Applicable only to maintenance holes with steps.

### 3.13 SLIP RESISTANCE

Maintenance hole benches shall have a slip-resistant surface and shall be in accordance with the requirements specified in Table 3.4 when tested in accordance with AS 4586.

**TABLE 3.4**

**SLIP RESISTANCE TEST REQUIREMENT**

Test Condition	Required Class
Appendix D: Oil-Wet inclining platform test method	R9
Appendix E: Displacement volume test method	V10

## 4 MANUFACTURE

### 4.1 DIMENSIONS OF THE BASE, CONE AND RISER

The wall thickness of the base, cone and riser measured in accordance with AS/NZS 1462.1, shall not be less than the benchmark design wall thickness nor less than the wall thickness specified in the relevant product standard, as appropriate.

### 4.2 WELDING

#### 4.2.1 PVC

Where hot-air (rod) welding is performed, all welds shall be partial penetration welds to at least 75% of the wall thickness of the sections being welded. All welding procedures shall be pre-qualified.



#### 4.2.2 PE and PP

Where welding is required for fabrication of components butt welding, extrusion welding or electrofusion welding may be used. All welding procedures shall be pre-qualified.

#### 4.2.3 Training and certification

Only duly certified welders shall perform welding of components. The welding of components shall be carried out and supervised by qualified accredited personnel who have successfully undertaken an acceptable (e.g. internationally recognised) plastics welding course or who has undertaken the following Units of PMB07 – Competence of Plastics, Rubber and/or Cable making training package appropriate to the welding processes used:

- (a) PMBPROD287B—Weld plastics materials.
- (b) PMBWELD301B—Butt weld polyethylene plastic pipelines.
- (c) PMBWELD302B—Electrofusion weld polyethylene pipelines.
- (d) PMBWELD309B—Weld plastics using extrusion techniques.

'Successfully undertaken' shall mean an award of a 'Statement of Attainment' for all the relevant units of competence.

### 4.3 SOLVENT CEMENT JOINTING

Where solvent cement jointing of a PVC-U pipe or fitting component is required, it shall be performed in accordance with the procedures outlined in AS/NZS 2032. The gap filling cement nominated by the fittings supplier shall be used when jointing PVC-U pipe fittings with parallel sockets.

### 4.4 MAINTENANCE HOLE STEPS AND LADDERS

Steps or ladders forming part of the maintenance hole construction shall comply with either EN 13101 or EN 14396 as appropriate.

### 4.5 STRUCTURAL ADHESIVE JOINTS

Structural Adhesive joints shall only be produced in a controlled manufacturing environment and not in the field.

## 5 MARKING REQUIREMENTS

### 5.1 GENERAL

Maintenance shafts, maintenance chambers, maintenance holes and components shall be legibly and permanently marked with the following:

- (a) Manufacturer's name or registered trademark.
- (b) Date of manufacture identified by at least the month and year.
- (c) Material identification in the form 'PVC-U' (or 'PVC'), 'PE', 'PP' or 'PP-MD' as appropriate.
- (d) Nominal size in the form 'DN 100' or '100' for connections and 'DN 300' or '300' for risers.
- (e) Configuration if the base includes a junction or change in direction.
- (f) Identification of the place of manufacture if the manufacturer is producing the product in more than one location either nationally or internationally. The manufacturer's code is acceptable, e.g. 'P1'.
- (g) Maximum installation depth in the form  $H_{Max}$
- (h) The number of this Industry Standard.

Risers shall be marked in accordance with the appropriate product Standard listed in [Table 2.1](#), or as for maintenance shafts, maintenance chambers and maintenance hole above.

Marking shall not be by means of sharp instruments that could potentially initiate cracks or other types of defects and hence adversely affect the performance of the maintenance shaft, maintenance chamber or maintenance hole.

Marking by indentation shall ensure that wall thickness is never reduced by more than 0.25 mm.

The size of the marking shall be such as to be clearly visible without magnification aids.

NOTE: Manufacturers making a statement of compliance with this Standard on a product, packaging, or promotional material related to that product should ensure that such compliance is capable of being verified.

## 5.2 ADDITIONAL INFORMATION

The manufacturer shall nominate configuration and installation parameters on which product design was based including:

- (a) Worst case permissible soil classification/grading and compactive density.
- (b) Highest permissible vehicular traffic loading impacts (e.g. Class D or 240 kN ultimate loading as defined in AS 3996).
- (c) Specified cover solution.
- (d) Size and material specifications for the pipes to which the shaft/chamber is intended to be connected.
- (e) Drawing of typical shaft/chamber product assemblies including near-surface components with all primary dimensions nominated.

## APPENDIX A

### MEANS OF DEMONSTRATING COMPLIANCE WITH THIS STANDARD

(Normative)

#### A1 SCOPE

This Appendix sets out two means by which compliance with this Standard shall be demonstrated by a manufacturer, as follows:

- (a) The use of a product certification scheme
- (b) The use of a minimum sampling and testing frequency plan.

#### A2 RELEVANCE

The long-term performance of pipeline systems is critical to the operating efficiency of water agencies in terms of operating licences and customer contracts. The long-term performance of plumbing systems is similarly critical to the durability of building infrastructure, protection of public health and safety and protection of the environment.

#### A3 BATCH

##### A3.1 Acceptable quality level (AQL)

When a continuous series of lots or batches is considered, the quality level which for the purpose of sampling inspection is the limit of a satisfactory process average (see AS 1199.1 and ISO 3951 Parts 1, 2, 3 and 5).

NOTE: The designation of an AQL does not imply that a manufacturer has the right to knowingly supply any non-conforming unit of product.

##### A3.2 Batch

###### A3.2.1 Material or compound batch

A defined quantity of a homogeneous material or compound produced under uniform conditions. The batch is defined and identified by the material or compound producer.

###### A3.2.2 Pipes or fittings batch

Schedule of pipes or fittings, all the same nominal diameter, wall thickness and marking, manufactured from the same material or compound on the same machine. The batch is defined and identified by the pipe or fitting manufacturer.

##### A3.3 Batch release test

A test performed on a sample from the batch or lot to confirm conformance to the requirements of this Standard before the batch can be released.

##### A3.4 Inspection level

The relationship between the lot or batch size and the sample size (see AS 1199.1).

##### A3.5 Lot

A clearly identifiable subdivision of a batch for inspection purposes.

##### A3.6 New formulation

A change in material or compound formulation that exceeds the limits given in [Clause A6](#).

##### A3.7 Process verification test (PVT)

A test performed on a sample at specific intervals to confirm conformance to the requirements of this Standard before further batches can be released.

### **A3.8 Sample**

One or more units of product drawn from a batch or lot, selected at random without regard to quality.

NOTE: The number of units of product in the sample is the sample size.

### **A3.9 Sampling plan**

A specific plan that gives the number of samples and the frequency of inspection or testing.

### **A3.10 Type test (TT)**

A test performed on a sample to confirm conformance to the requirements of this Standard before any batches can be released.

## **A4 PRODUCT CERTIFICATION**

A4.1 Products claiming conformity with this Standard shall be certified.

NOTE Product certification is an impartial third-party attestation that the products conform to this Standard.

A4.2 The certification scheme to undertake the production certification shall:

- (a) be based on ISO/IEC TR 17026, Conformity assessment -- Example of a certification scheme for tangible products;
- (b) include type testing from independently sampled production;
- (c) require the manufacturer's production process to be covered by a quality management system that fulfils the requirements of AS/NZS ISO 9001, Quality management systems - Requirements; and
- (d) include subsequent verification of conformance that the manufacturer maintains effective production control, at no greater than 12 monthly interval.

NOTE: The certification scheme serves to indicate that the products consistently conform to the requirements of this Standard.

The frequency of the sampling and testing plan, as detailed in [Clause A5](#), shall be used by the certifying body for product compliance auditing. However, where the manufacturer can demonstrate adequate process control to the certifying body, the frequency of sampling and testing nominated in the manufacturer's quality and/or documented procedures shall take precedence for the purpose of product certification.

Product certification shall be conducted by a certification body that is accredited as fulfilling the requirements for AS/NZS ISO/IEC 17065, Conformity assessment - Requirements for bodies certifying products, processes and services, by a signatory member of the International Accreditation Forum (IAF) Multilateral Arrangement (MLA), with a relevant scope of accreditation to cover the products being certified.

NOTE In Australia, the signatory member of the IAF MLA is the Joint Accreditation System of Australia and New Zealand (JAS-ANZ).

## **A5 MINIMUM SAMPLING AND TESTING FREQUENCY PLAN**

### **A5.1 General**

[Table A1](#) sets out the minimum sampling and testing frequency plan for a manufacturer to demonstrate compliance of product(s) to this Standard.

### **A5.2 Retesting**

In the event of a test failure, the products manufactured since the previous test(s) conforming to the requirements outlined in [Table A1](#) shall be quarantined as a batch. A further set of samples shall be selected randomly from the quarantined batch using a sampling plan to AS 1199.1 for an AQL of 2.5 and an inspection level of S3, unless otherwise specified. If the

retest requirements are met, the batch may be released and compliance with this Standard for the quarantined batch may be claimed. Should a failure occur on retesting, then the quarantined batch shall be rejected and claims and/or marking indicating compliance to this Standard shall be suspended until the cause of the failure has been identified and corrected.

### A5.3 Rejection after test

In the event of a quarantined batch being rejected after retesting in accordance with the procedures set out in Clause A5.2, it may be subjected to 100% testing for the failed requirement(s), and only those items found to comply may be claimed and/or marked as complying with this Standard.

**TABLE A1**  
**MINIMUM SAMPLING AND TESTING FREQUENCY PLAN**

Type tests				
Characteristics	Clause	Requirement	Test method	Frequency
<b>Material requirements</b>				
Materials General	2.2.1	No lead, cadmium or mercury based additives	Process control records	At any change in material formulation, design or process
Materials for bases	2.2.2	Material compliance of standard materials  Material compliance of non-standard materials  Durability of standard and non-standard materials: no cracks after 1000 h or 3000 h as appropriate	Confirm third party certification for any materials or components for which compliance with <a href="#">Table 2.1</a> is claimed  Compliance with <a href="#">Clause B5</a> of Appendix B  ISO 13267 and <a href="#">Appendix B</a>	
Materials for risers, cones and caps	2.2.3	Material compliance of standard materials  Material compliance of non-standard materials	Confirm compliance with <a href="#">Clause 2.2</a> or third party certification for any risers for which compliance with AS/NZS 1477, AS/NZS 4441 or AS/NZS 4765 is claimed  Compliance with Appendix B <a href="#">Clause B5</a>	
Rework	2.2.4	Confirmation that only rework from manufacturer's own production is used.	Process control records	

<b>Type tests</b>				
<b>Characteristics</b>	<b>Clause</b>	<b>Requirement</b>	<b>Test method</b>	<b>Frequency</b>
Elastomeric seals	2.2.5	Compliance with AS 1646 and AS 681.1 or AS 681.2	Product certification to AS 1646 and AS 681.1 or AS 681.2	
Solvent cements	2.2.6	Compliance with AS/NZS 3879	Product certification to AS/NZS 3879	
Structural adhesives	2.2.7	Compliance WSA PS – 287	Product certification to WSA PS – 287	
<b>Material requirements</b>				
Freedom from defects	2.3	Structural and surface defects, condition of sockets and spigot ends, smoothness of internal joints, condition of elastomeric seals.	Visual examination	At any change in material formulation, design or process
Dimensions of sockets and spigots and effective sealing length	2.2.4	Compliance with appropriate product Standard, drawing or specification	AS/NZS 1462.1	At any change in material formulation, design or process
Packaging, storage, handling and transportation	2.6	Specific requirements for storage depending on material properties Stacking to maintain dimensions and protects ends and projections	Review of manufacturer's instructions and visual verification of storage conditions	
<b>Performance requirements</b>				
Structural integrity of base	3.2	50 year predicted vertical deflections ≤5% and horizontal deflections ≤10%	Appendix C and ISO 13267	At any change in material formulation, design or process
Impact resistance of base	3.3	No cracks or other damage that impairs the function of the base	Appendix E	
Ring stiffness of riser	3.4	Ring stiffness ≥4,000 N/m/m	AS/NZS 1462.22	
High temperature stress relief	3.5	No voids, contaminations or delaminations etc. as described in <a href="#">Clause 3.5</a>	AS/NZS 1462.11	
Accessibility test	3.6	Passes appropriate proving tool(s) through all connection ports	3.6	
Elastomeric seal joints between pipe and base	3.7.2	No leakage	ISO 13259 Condition D	

<b>Type tests</b>				
<b>Characteristics</b>	<b>Clause</b>	<b>Requirement</b>	<b>Test method</b>	<b>Frequency</b>
Elastomeric seal joints between the riser and base	3.7.3	No leakage	ISO 13259 Condition A	
<b>Performance requirements</b>				
Watertightness between the riser and accompanying components	3.7.4	No leakage	No leakage after 15 min when assembly filled with water.	At any change in material formulation, design or process
Watertightness of telescopic section of riser	3.7.4	No leakage	No leakage after 15 min when assembly filled with water	
Watertightness of cone section	3.7.4	No leakage	No leakage after 15 min when assembly filled with water	
Watertightness of Riser inlet connector	3.7.4	No Leakage	No leakage after 15 min when assembly filled with water	
Effective seal	3.7.5	Contact pressure $\geq 0.4$ MPa for vulcanised seals and 0.47 MPa for thermoplastic elastomeric seals over a contact width $>4$ mm	AS/NZS 1462.13	
Integrity of Cap and seal – liquid infiltration test	3.8.2	No leakage	AS/NZS 1462.8	At any change in material formulation, design or process
Characterisation of rotationally moulded product.	3.9	Weight variation In accordance with Table 3.3	Weighing machine with a precision of at least 0.5% of the product weight	
Riser and riser joint load resistance	3.10	Withstand frictional down-drag forces of surrounding soil	By design or testing in accordance with <a href="#">Appendix D</a>	
Load bearing capacity of cone and near surface components	3.11.2	No visible cracking, collapse, or other similar form of structural failure.	ISO 13266	
Maintenance hole steps – load bearing resistance	3.12.1	Deformation under load $\leq 10$ mm. Residual deformation $\leq 5$ mm	EN 13101	
Maintenance hole steps – pull-out resistance	3.12.2	No pull-out with an applied horizontal force of 1 kN	EN 13101	
Slip resistance	3.13	R9	AS 4586 Appendix D	
		V10	AS 4586 Appendix E	
<b>Manufacture</b>				
Dimensions of base and riser	4.1	Not less than the design thickness or thickness of relevant Standard as appropriate	AS/NZS 1462.1	At any change in material formulation, design or process.

<b>Type tests</b>				
<b>Characteristics</b>	<b>Clause</b>	<b>Requirement</b>	<b>Test method</b>	<b>Frequency</b>
Welding	4.2	In accordance with <a href="#">Clause 4.2.3</a> and <a href="#">Clause 4.2.1</a> or <a href="#">4.2.2</a> as appropriate	Visual verification and process control	
Solvent cement jointing	4.3	AS/NZS 2032	Visual verification and process control	
Structural adhesives	2.2.7	Compliance with Appendix F and WSA PS – 287	Visual verification and process control	

<b>Batch release tests</b>				
<b>Characteristics</b>	<b>Clause</b>	<b>Requirement</b>	<b>Test method</b>	<b>Frequency</b>
Freedom from defects	2.3	Structural and surface defects, condition of sockets and spigot ends, smoothness of internal joints, condition of elastomeric seals.	Visual verification	At start up and once per shift
Dimensions of sockets and spigots and effective sealing length	2.4	Compliance with appropriate product Standard, drawing or specification	AS/NZS 1462.1	Once per shift or once per batch, whichever is the more frequent
Packaging, storage, handling and transportation	2.6	Compliance with appropriate installation Standard, product drawing or specification	Visual examination	Once per shift
Ring stiffness of riser	3.4	Ring stiffness $\geq 4,000$ N/m/m	AS/NZS 1462.22	At start up and once per week or once per batch, whichever is the more frequent
High temperature stress relief (PVC-U)	3.5	No voids, contaminations or delaminations etc. as described in <a href="#">Clause 3.5</a>	AS/NZS 1462.11	At start up and once per shift
Weight of rotationally moulded products	3.9	<a href="#">Table 3.3</a>	Weighing machine with a precision of at least 0.5% of the product weight	
Dimensions of base and riser	3.1	Wall thickness not less than design wall thickness or relevant product Standard as appropriate	AS/NZS 1462.1	At start up and once per shift
Welding	3.2	Welding to be in accordance with nominated specification	Visual verification	
Solvent cement jointing	3.3	Evidence of application of primer and absence of excess cement and	Visual verification	



Batch release tests				
Characteristics	Clause	Requirement	Test method	Frequency
		joint made in accordance with AS/NZS 2032		
Structural adhesives	2.2.7	Evidence of structural adhesives joint made in accordance with WSA PS – 287		
Marking	5	Complete, legible and permanent	Visual examination and comparison with production records	Each assembly Injection mouldings once per shift

Process verification tests				
Characteristics	Clause	Requirement	Test method	Frequency
Materials General	2.2.	Material compliance	Confirm third party certification for any materials or components for which compliance with <a href="#">Table 2.1</a> is claimed	Once per 2 years
Durability of standard and non-standard materials for bases	2.2.2.1 and 2.2.2.2	No cracks	<a href="#">Appendix B</a> and ISO 13267	Once per year
Characterisation of non-standard materials for risers, cones and caps	2.2.3.2	Table B2	<a href="#">Appendix B Clause B5</a>	
Rework	2.2.4	Confirmation only rework from manufacturer's own production is used	Process control records	
Elastomeric seals	2.2.5	Compliance with AS1646	Product certification to AS 1646	Once per 2 years
Solvent cements	2.2.6	Compliance with AS/NZS 3879	Product certification to AS/NZS 3879	
Structural adhesives	2.2.7	Compliance with <a href="#">Appendix F</a> and WSA PS – 287	Product certification to WSA PS – 287	
Impact resistance of maintenance base	3.3	No cracks or other damage that impairs the function of the base	<a href="#">Appendix E</a>	
Elastomeric seal joints between pipe and base	3.7.2	No leakage	ISO 13259 Condition D	
Elastomeric seal joints between the riser and base	3.7.3	No leakage	ISO 13259 Condition A	Once per 2 years
Water tightness between the riser	3.7.4	No leakage	No leakage after 15 minutes when	

Process verification tests				
Characteristics	Clause	Requirement	Test method	Frequency
and accompanying components			assembly filled with water	
Water tightness of telescopic section of riser	3.7.4	No leakage	No leakage after 15 minutes when assembly filled with water	
Water tightness of cone section	3.7.4	No leakage	No leakage after 15 minutes when assembly filled with water	
Watertightness of Riser inlet connector	3.7.4	No Leakage	No leakage after 15 min when assembly filled with water	
Integrity of cap and seal – liquid infiltration test	3.8	No leakage	AS/NZS 1462.8	
Riser and riser joint load resistance	3.10	Withstand frictional down-drag forces of surrounding soil	By design or testing in accordance with <a href="#">Appendix D</a>	
Load bearing capacity of cone and near surface components	3.11.2	No visible cracking, collapse, or other similar form of structural failure.	ISO 13266	Once per 5 years
Maintenance hole steps – load bearing resistance	3.12.1	Deformation under load $\leq 10$ mm. Residual deformation $\leq 5$ mm	EN 13101	Once per 2 years
Maintenance hole steps – pull-out resistance	3.21.2	No pull-out with an applied horizontal force of 1 kN	EN 13101	

## A6 NEW FORMULATION

A change in the material / compound formulation occurs when the dosage level of ingredients exceeds the tolerances in Clauses A6.1, A6.2 or A6.3 as appropriate.

### A6.1 Material specification of PVC-U

For the purposes of this Standard, the material specification consists of a formulation which defines the K value of the PVC, the nature of the additives and their dosage levels. The dosage level of ingredients of a PVC formulation shall not exceed the tolerance bands given in [Table A2](#).

If any level exceeds the dosage band or if an ingredient type is changed, this variation in formulation constitutes a change in material.

Rework material from the manufacturer's own production that involves like materials shall be permissible.

The values of the parts X added to 100 parts by mass of PVC shall be specified in the manufacturer's production quality plan.

**TABLE A2**  
**FORMULATION SPECIFICATION FOR PVC**

Ingredients	Type	Band
PVC resin	Nominal K value: as specified	$\pm 3$ units
Type and content of stabiliser or master batch	1) Ça-Zn 2) Sn 3) Ca-Sn 4) others	X1: $\pm 25\%$
Lubricants	All	X2: $\pm 50\%$ for X2 <0.2 X2: $\pm 0.1$ parts for X2 >0.2
Fillers	1) CaCO <sub>3</sub> 2) others	X3: $\pm 3$ parts X4: $\pm 25\%$
Impact modifiers	All	X5: $\pm 1$ part
Flow agents/ processing aids	All	X6: $\pm 25\%$ for X6 $\leq 2$ X6: $\pm 0.5$ parts for X6 >2
Pigments		No requirement
Others	To be specified by the manufacturer	X7: $\pm 25\%$

NOTE : X is the original determined value, specified in the manufacturer's production quality plan.

#### **A6.2 Material specification for PP and PP-MD**

For the purposes of this Standard, a PP or PP-MD material consists of a compound having a recognised trade name and additives with known dosage levels.

Rework material from the manufacturer's own production that involves like materials shall be permissible.

A change of commercial compounds utilised in the manufacture of maintenance shaft/chamber/hole components shall require re-certification of the production components affected.

#### **A6.3 Material specification for PE**

For the purposes of this Standard, a PE material consists of a compound having a recognised PE trade name and additives with known dosage levels.

Rework material from the manufacturer's own production that involves like materials shall be permissible.

## APPENDIX B

### DURABILITY AND MATERIAL TESTING

(Normative)

#### B1 SCOPE

This appendix sets out the requirements for determining the durability of standard and non-standard materials and the material characteristics of non-standard materials used in specific maintenance shaft, maintenance chamber and maintenance hole designs.

#### B2 APPLICATION

This appendix is applicable to maintenance shafts, maintenance chamber and maintenance hole bases manufactured from standard materials and bases, risers, cones and caps manufactured from non-standard materials (refer to [Clauses 2.2.2](#) and [2.2.3](#)).

#### B3 SAMPLES

Two maintenance shafts, maintenance chambers or maintenance holes shall be selected for testing. The base of one shaft/chamber shall be subjected to the durability test and the components of the other used to determine the material properties.

#### B4 TEST PROCEDURE

The durability of maintenance shaft, maintenance chamber or maintenance hole bases shall be determined in accordance with ISO 13267 and the test parameters and rating factors given in Table B1. At the duration of the test the base shall be cooled to room temperature, inspected and deemed conforming where no cracking is evident.

**TABLE B1**  
**TEST PARAMETERS**

Material	Test temperature °C	Rating Factor R (applicable to standard and non-standard materials)
PVC-U	60 ± 2	3.5
PE	80 ± 2	4.1
PE rotational moulded	60 ± 2	3.6
PP	80 ± 2	3.4
PP rotational moulded	80 ± 2	3.6

#### B5 NON-STANDARD MATERIAL CHARACTERISTICS

Material taken from the other (second) maintenance shaft, maintenance chamber or maintenance hole sample shall be tested for the appropriate characteristics in [Table B2](#). Where a mixture of non-standard materials is used for bases, risers, cones and caps, each non-standard material shall be separately tested for conformity.

**TABLE B2**  
**MATERIAL CHARACTERISTICS**

Characteristics	Test method	Requirement	Rotational moulded		Injection moulded		
			PE	PP	PE	PP <sup>2</sup>	PVC-U
Density <sup>1</sup>	ISO 1183-1 or ISO 1183-2	Maximum deviation from agreed value (kg/m <sup>3</sup> )	±25	±25	±25	±25	±25
Oxidation induction time (OIT) at 200°C	ISO 11357-6	(minutes)	≥10	≥8	≥10	≥8	NA
K value <sup>3</sup>	ISO 13229		NA	NA	NA	NA	±3
MFR <sup>4</sup>	ISO 1133 <sup>5</sup>	Maximum upper deviation from agreed value	$X^6 > 1.5$ : $X \leq 1.5$		+20% +0.3 g/10min		NA

'NA' denotes 'Not applicable'.

**NOTES**

- 1 Not required for PE complying with AS/NZS 4131, PVC-U complying with AS/NZS 1260 or low pressure moulding materials.
- 2 For low pressure injection moulded PP components, (melt pressure less than 1400 kPa) the maximum upper deviation can be 100% for MFR <2.0.
- 3 Not required for PVC-U complying with AS/NZS 1260.
- 4 No lower limit is placed on the deviation of the MFR.
- 5 For moulded or fabricated PE use condition T, for rotational moulded PE use condition D and for PP use condition M.
- 6 X is the original determined value.

**APPENDIX C**  
**STRUCTURAL INTEGRITY OF BASE**  
(Normative)

**C1 GENERAL**

The structural integrity of bases shall be determined as the predicted 50 year deflection at ambient temperatures as described below.

**C2 TEST PROCEDURE**

The structural integrity of bases shall be determined in accordance with the test procedure given in ISO 13267.

**C3 EVALUATION OF DATA**

The 50-years deformation can be calculated as described in ISO 13267.

NOTE 1: For the predicted final deformation in the vertical, and the horizontal directions respectively, the final result according to this method of calculation is as follows:

$$(\delta/d)_v = Y_{50,v}/d \text{ and } (\delta/d)_h = Y_{50,h}/d.$$

where  $d$  is the nominal width of the flow profile.

If the predicted 50 years vertical deformation is higher than 2% or the horizontal deformation is higher than 4%, the correlation coefficient shall at least be 0.9. In all other cases, the correlation coefficient shall be ignored.

NOTE 2: When the deformation in the horizontal direction (width of flow profile) is less than 10%, normal inspection and cleaning equipment can be entered in the sewer system. When the deformation in the vertical direction is less than 5%, effects on flow performance can be neglected.

**APPENDIX D**  
**METHOD FOR LOAD TESTING**  
(Normative)

**D1 SCOPE AND GENERAL****D1.1 Scope**

This Appendix sets out a method for the load testing of a maintenance shaft, maintenance chamber or maintenance hole to demonstrate its ability to adequately resist riser movement during and after installation. Following application of the test load, the maintenance shaft maintenance chamber or maintenance hole shall be tested for hydrostatic resistance to leakage and structural resistance to buckling by means of an applied negative internal pressure. Riser and riser joint(s) shall be designed to withstand typical mechanical impact and frictional down-drag forces generated by embedment surround and backfill installation procedures and by subsequent post-installation movement by demonstrating the stability of joint seal integrity and disposition.

A design shall be considered adequate for this purpose where it incorporates a telescopic riser or an elastomeric seal jointed system that demonstrates acceptable joint movement tolerances (e.g. > 30 mm) and resistance to movement.

**D1.2 Relevance of test**

Maintenance shaft, maintenance chamber or maintenance hole risers are required to withstand typical mechanical impact and frictional down-drag forces generated by embedment surround and backfill installation procedures and by subsequent post-installation movement.

**D1.3 Preparation of test assemblies**

Each test assembly shall comprise a maintenance shaft, maintenance chamber or maintenance hole assembled with a riser and connecting 'pipe' stubs at least 300 mm in length.

**D2 TEST PROCEDURE - LOAD TESTING****D2.1 Principle**

A test assembly is subjected to a load and then a partial internal vacuum.

**D2.2 Apparatus**

The following apparatus is required:

- (a) Testing stand—A structurally rigid stand, to be used as a support for the test assemblies.
- (b) Supports—At each end of the maintenance shaft, maintenance chamber or maintenance hole, the centre-line of the collar shall be supported by a cradle of matching radius with an arc subtending an angle of 90°. Each cradle shall have a width of 50 mm and be mounted on a pinned roller support.
- (c) Bearing block—A sufficiently rigid bearing block, to ensure that the load on the riser cap is evenly distributed.
- (d) Testing device—A device or other means of load application, such as a hydraulic testing machine or pre-weighed elements, such as ingots, sand-filled bags or other suitable means, for applying the load. The device shall be capable of applying a load greater than the specified test load.

**D2.3 Procedure**

The procedure shall be as follows:

- (a) Secure and condition the test assembly at 20–25°C for 2 +0.5, -0 h within the test stand, so that the load may be applied to the riser cap.

- (b) Place the bearing block on the riser cap.
- (c) Apply a test load of  $15 \pm 0.5$ ,  $-0$  kN, without shock, to the assembly through the bearing block.
- (d) Sustain the load for a minimum of 5 min.
- (e) Measure the change in external dimensions in accordance with AS/NZS 1462.1.
- (f) Release and/or remove the test load.
- (g) Inspect and record any evidence of damage including any buckling or collapse and for maintenance shafts, maintenance chambers and maintenance holes with reinforcement, any separation between the maintenance shaft or maintenance chamber and its reinforcement, and any delamination, cracking or splitting of the reinforcement.
- (h) Within 24 h, continue the vacuum testing in accordance with Clause D3.

### **D3 TEST PROCEDURE - VACUUM**

#### **D3.1 Principle**

A test assembly is subjected to an internal vacuum. The assembly is then inspected for distortion.

#### **D3.2 Apparatus**

The following apparatus is required:

- (a) End connections—Vacuum-tight connections shall be made to the test assembly within the socket, or on the external surface. Provision shall be made for connection to the vacuum system or venting of the pipe of specimen to atmosphere as required. Vacuum shall be applied through one of the end connections.
- (b) Pressurising system—A system capable of producing and maintaining the test vacuum pressure.

#### **D3.3 Procedure for vacuum test**

The procedure shall be as follows:

- (a) Secure and condition the test assembly at  $20\text{--}25^\circ\text{C}$  for  $2 \pm 0.5$ ,  $-0$  h.
- (b) Gradually apply an internal vacuum corresponding to a gauge pressure of 80 kPa to 85 kPa for  $15 \pm 1$ ,  $-0$  minutes.
- (c) At the completion of the test period measure the changes in external dimensions.
- (d) At the completion of the test period recording any buckling or collapse and for maintenance shafts, maintenance chambers or maintenance holes with reinforcement any separation between the maintenance shaft or maintenance chamber and its reinforcement, and any delamination, cracking or splitting of the reinforcement.

### **D4 TEST REPORT**

The following information shall be reported:

- (a) The unique identification of each maintenance shaft, maintenance chamber or maintenance hole assembly tested.
- (b) The test temperature ( $^\circ\text{C}$ ).
- (c) The test load applied to the assembly and the duration of the load test.
- (d) All changes in external dimensions due to the applied test load.
- (e) The vacuum test pressure applied to the assembly and the duration of the vacuum test (kPa).



- (f) All evidence of leakage detected during the vacuum test.
- (g) All changes in external dimensions due to the applied test vacuum (mm) pressure.
- (h) All evidence of structural buckling (or collapse) for each assembly with reinforcement
- (i) All evidence of separations between assembly component materials and material reinforcement and all evidence of delamination, cracking or splitting of material reinforcement.
- (j) Reference to this test method.

Public Comment Draft

**APPENDIX E**  
**IMPACT RESISTANCE OF BASE**  
(Normative)

**E1 TEST EQUIPMENT**

The test equipment shall be as given in ISO 3127.

**E2 RELEVANCE OF TEST**

The impact test is carried out under controlled and reproducible test laboratory conditions to provide a measure of the resistance of a base component to impact damage. The base component is not tested in an 'as installed' (or embedded in soil) configuration in order to assure its installed performance, with a serviceability safety factor to cover unknown and unpredictable conditions on various installation sites.

**E3 TEST PROCEDURE**

The procedure shall be as follows:

- (a) Place the complete maintenance shaft, maintenance chamber or maintenance hole base unit on a vee block in such a way that at least a 30 mm gap between base and block is achieved at point of impact.  

The test apparatus shall be modified as necessary to accommodate larger bases. The vee block may be eliminated, provided that a 30 mm gap remains between the end of the guiding pipe and point of impact and between the ground and the base unit at the point of impact.
- (b) Secure and condition the base at 20–25°C for 2 +0.5, –0 h.
- (c) Use a straight pipe with an internal diameter of 100 mm to 106 mm and a length of 2.5 m. Place one end of this pipe in the middle of the main flow profile of the base in a vertical position, perpendicular to the base.
- (d) Drop a striker type d90 (see ISO 3127) with mass 1 kg, from 2.5 m.
- (e) Inspect the impacted area for any evidence of cracking and other damage that might impair the function and performance of the base.

**E4 TEST REPORT**

The following information shall be reported:

- (a) The unique identification of each maintenance base unit tested.
- (b) The test temperature (°C).
- (c) The striker mass (kg).
- (d) The drop height (m).
- (e) The date of test.
- (f) All evidence of cracking or other damage that might impair the function and performance of the base.
- (g) Reference to this test method.

**APPENDIX F**  
**REQUIREMENTS FOR STRUCTURAL ADHESIVES**  
(Normative)

The supplier shall provide a data sheet defining the:

- (a) mixing ratios,
- (b) preparation and service temperatures,
- (c) working life of the prepared adhesive, and
- (d) the cure time.

NOTE The use of the adhesive to form joints should be restricted to a controlled environment

Public Comment Draft